



# Adaptive Digital Autopilot

NautoPilot® 20X5 Series





# Adaptive Digital Autopilot

## NautoPilot® 20X5 Series

*NautoPilot® 20X5 is Raytheon Anschütz' professional autopilot series* for all commercial ships of 100m length and above. It is characterized by the most advanced steering algorithms that ensure accurate steering with fewest rudder actions to keep the ship on a preset heading. Thus the NautoPilot 20X5 series reduces wear and tear on the steering gear and reduces fuel consumption – an important factor these days. NP 20X5 pays for itself.

### Features

NautoPilot 20X5 offers excellent steering properties and can easily be adjusted to all ship types, even to High Speed Craft (HSC). The Quick Tune function allows for the individual definition of 6 parameter sets to quickly adapt to the current environmental or ship condition. Turns are radius or rate-of-turn controlled. The adaptive autopilot can be used in Precision or Economy mode depending on the sea area. In Economy mode, the number of rudder actions are noticeably reduced with a positive effect on ship's fuel consumption.

The NautoPilot 20X5 series can be seamlessly integrated into a navigational system. Various in- and output interfaces come standard. Tillers and an Autopilot Remote Control Panel can be connected directly to the autopilot. It is also possible to connect a rate-of-turn tiller and a rate-of-turn gyro for river navigation. In combination with Raytheon Anschütz ECDIS, the autopilot becomes an approved track control system.

### Algorithms and Adaptivity

In general an autopilot is a controller that keeps a ship on a preset heading. The quality of this process is determined by the hardware and the software algorithms that control it. Both, hardware and software algorithms determine the accuracy of the heading control system. The number of rudder actions and the rudder angle used to keep the ship on preset heading are reduced to a minimum with Raytheon Anschütz autopilots – thanks to the longest experience in the market.

Adaptivity means an automatic adaptation of the autopilot to the current sea-state and weather. Frequent Rudder actions that will not compensate the heading deviation due to the environmental conditions will be eliminated automatically by the autopilot. Therefore, the autopilot adapts continuously to the current sea-state and weather without a manual change of autopilot parameters.

Both, steering algorithms and adaptivity are core know-how of the autopilot manufacturer and are based on decades of experience. They are the basis for accuracy, reduce fuel consumption and wear and tear on the steering gear.

The operator unit provides clear information about heading, set course, alarms and warnings. A new course is set by dialing and pushing a rotary knob.



The Autopilot Remote Control Panel can be installed at the Radar or ECDIS workstation where the navigation data is displayed. The tiller allows manual override at any time.



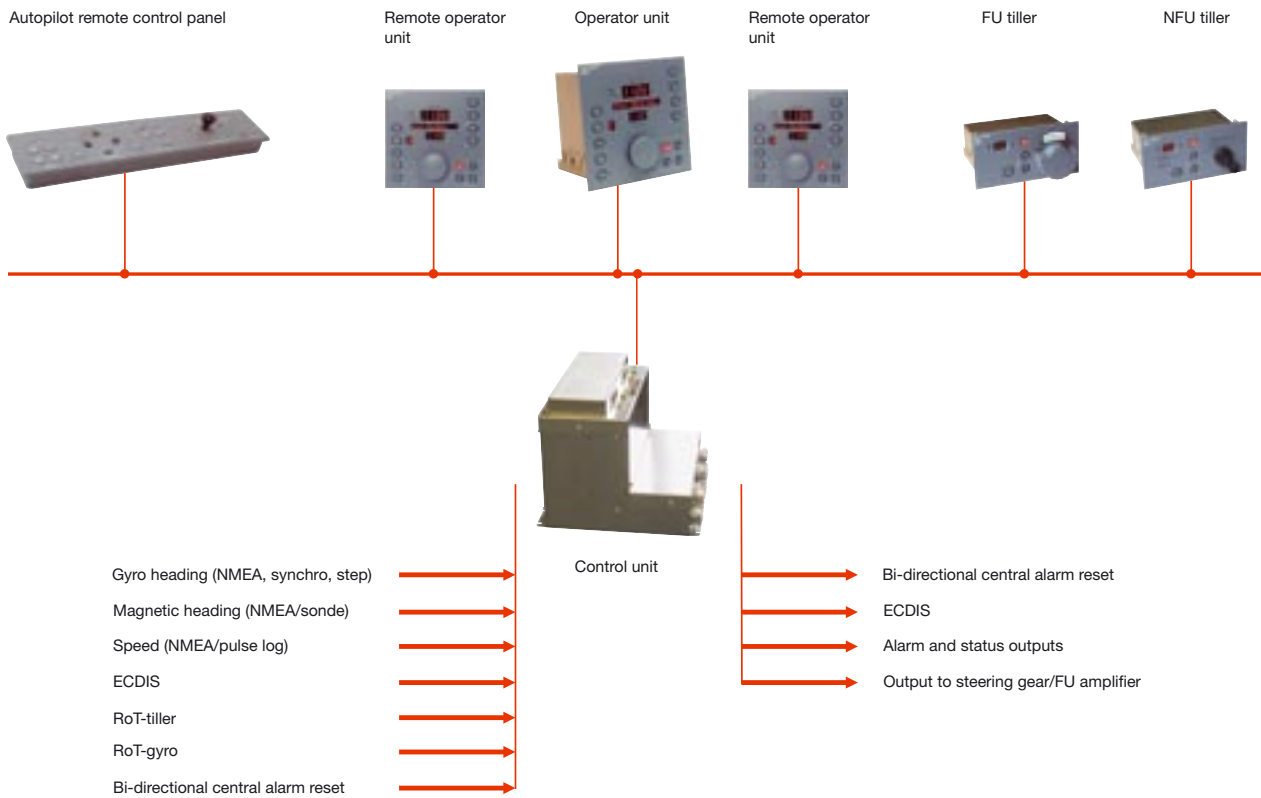

## Versions

### Nautopilot 2015

Quick Tune: 6 different parameter sets for preselection of rudder, counter rudder and yawing for fast adaptation to current sea-state.

It fulfils the requirements for a track control system, Category B, in combination with Raytheon Anschütz ECDIS.

### Nautopilot 2025

Offers, in addition to NautoPilot 2015, an Economy mode. This mode uses weather adaptivity to automatically optimize the rudder action for the current weather condition and sea-state. It meets the requirements for a track control system, Category B, in combination with Raytheon Anschütz ECDIS. The Nautopilot 2025 PLUS fulfils the requirements for track control system, Category C, in combination with Raytheon Anschütz ECDIS.

### Nautopilot 2035

The NautoPilot 2035 is also an adaptive autopilot. It uses a very fast / high precision controller and is intended for use in areas where highest precision is required. Nautopilot 2035 fulfils the requirements for track control system, Category C, and is used in combination with Raytheon Anschütz Integrated Bridge Systems.

## Benefits

- Precise steering
- Cost savings in reduced fuel consumption
- Reliable technology already installed on thousands of ships
- Suitable for a wide range of ship types, even High Speed Craft
- Qualifies as track control system Category B or C in combination with ECDIS
- Seamless integration into navigation system
- Ease of use and clear data display

## Technical Data

### Supply Voltage

24 V DC (18-36 V DC)

### Power Consumption

Approx. 25 W

### Signal Inputs

#### Gyro compass / satellite compass

- Course bus or NMEA telegrams HEHDT, GPHDT
- Synchro (50/20 V)
- 6 steps per degree

#### Magnetic compass / Fluxgate

- NMEA telegrams HCHDT, IIHDM
- With magnetic compass sonde 108-010

### Speed log

- NMEA telegrams VTG, VHW
- 200 pulses/nm

### ECDIS (for track control)

- According to IEC 62065, NMEA telegrams APB, XTE
- Remote control with NMEA telegrams HSC, HTR, HRA

### Signal Outputs

#### Outputs to steering gear

- 2 switching outputs (110 V DC – 0.5 A; 24 V DC – 2.0 A)
- 2 analog outputs (+/- 10 V DC – max. 5 mA)

#### Status/alarm outputs

- Off-heading
- Heading monitor
- System failure
- Power failure
- Track control active
- Magnetic compass selected
- Tiller active
- Bi-directional central alarm reset (optional)
- Override ON
- Back-up navigator alarm (in track control)

#### In accordance with

- ISO/IEC 11674
  - NMEA according to EN/IEC 61162-1
  - EN/IEC 60945
  - ISO 16329
  - A.342(IX), A.694(17), MSC.64(67) Annex 3, A.822(19)
- For details refer to EC-type examination certificate.

#### Type of enclosure acc. to IEC/EN 60529

- Operator Unit: IP 23
- Control Unit: IP 22

### General Data

#### Permissible ambient temperature

- Operation: -15°C to + 55°C
- Storage: -25°C to + 70°C

NautoPilot® is a registered trademark of Raytheon Anschütz GmbH

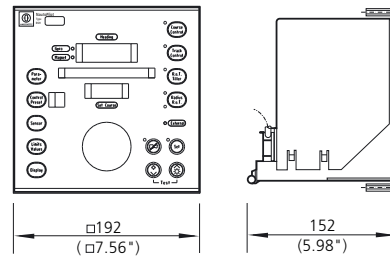

Operator unit 2.0 kg

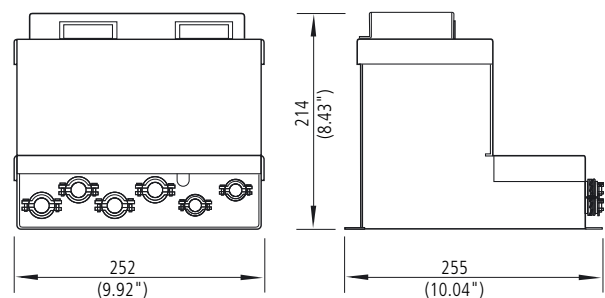

Control unit 5.2 kg

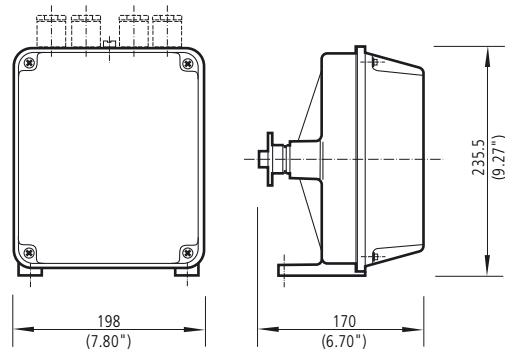

Feedback unit 4.0 kg

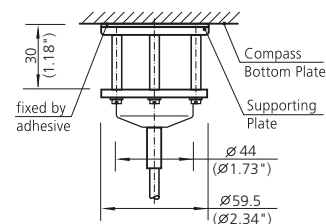

Magnetic compass sonde 0.4 kg